



by



Admiral Craft

Equipment Corp.

Solid Door Reach-In Refrigerators



Grista's Solid Door Reach-In Refrigerators are constructed of a heavy duty stainless steel exterior making them strong and durable enough to survive any kitchen environment. The cooling units are bottom mounted and slide out for easy maintenance and cleaning. All models come with 4" casters and plastic coated wire shelving that is easily removable to adjust the shelf height. The front digital controllers and LED readout makes it easy to adjust the interior temperature. These models are ETL Listed and ETL Sanitation. They are backed with a 1 year warranty on parts and labor and a 5 year warranty on the compressor.

Product Features

- Easy to clean 430 series stainless steel exterior
- Painted white aluminum interior
- Digital temperature control ranges 33-40°F in refrigerators and -7°F - 0°F in freezers
- 3 epoxy coated corrosion resistant shelves with 90 lb. capacity each
- Self-closing door with stay open feature beyond 90°
- Bottom mounted condensing unit positioned for easy maintenance
- Preprogrammed digital control featuring auto defrost cycle
- Foamed in place insulation helps provide strength while helping to maintain internal temperature
- Eco-friendly R290 hydrocarbon refrigerant
- Ships complete with casters



GRRF-1D



GRRF-2D



Specifications

Model Number	GRRF-1D	GRRF-2D
Doors	1	2
Shelves	3	6
Net Volume (Cu. Ft.)	23	48
Overall Dimensions (in)	29"W x 32"D x 82"H	54"W x 32"D x 82"H
Interior Dimensions (in)	24"W x 27"D x 60"H	49"W x 27"D x 60"H
Horsepower	1/5	1/4+
Refrigerant	R290	R290
Voltage/Hertz/Phase	115/60/1	115/60/1
Amps	2.6	3.8
Net Weight (lbs)	278 lbs	445 lbs
Gross Weight (lbs)	322 lbs	512 lbs
Shipping Dimensions (in)	31"L x 35"W x 83"H	56"L x 35"W x 83"H

CALL FOR MORE INFO: 1.800.223.7750

VISIT: www.admiralcraft.com

Solid Door Reach-In Refrigerators

Plan Views

GRRF-1D

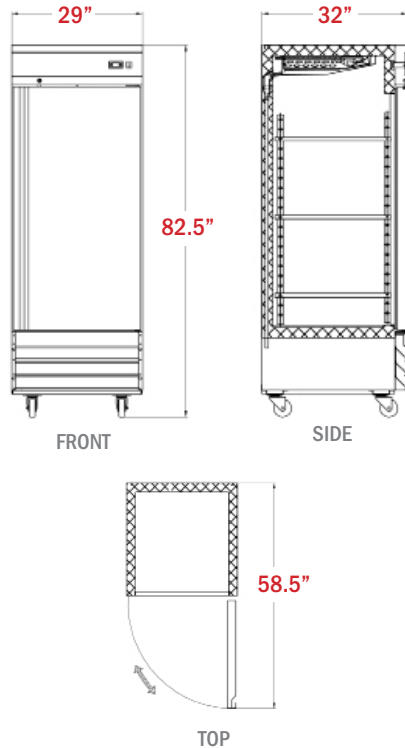

GRRF-2D

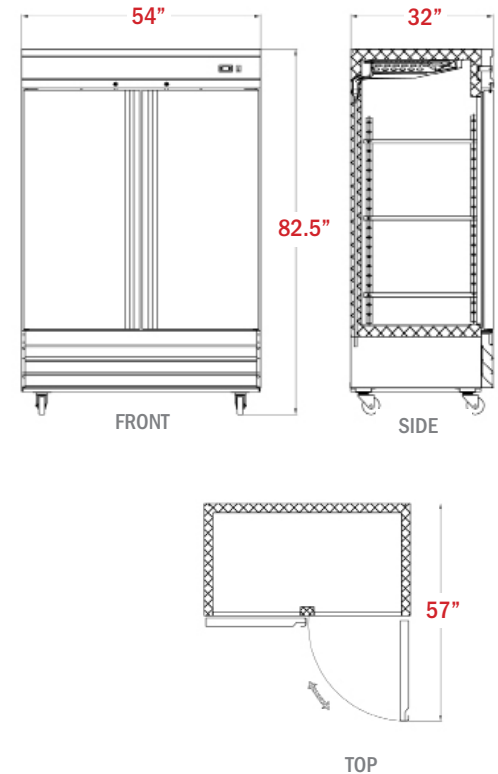

Features

Cooling System

- Refrigeration units use environmentally friendly R290 refrigerant that maintain a temperature range of 33°-40°F
- Bottom mounted cooling unit slides out for easy cleaning and maintenance and allows for storage area on top of the unit
- Rugged built axial evaporator fans run efficiently with low velocity and high volume air flow

Electrical Control

- Electric LED temperature controller provides a digital display of cabinet temperatures and allows for easy temperature adjustments when necessary
- Temperature controller initiates automatic defrost schedule for worry free use
- 7 foot power cord with NEMA 5-15 plug



Cabinet Construction

- Exterior is constructed of 430 stainless steel including the doors
- Interior is constructed of a painted aluminum liner
- The cabinet is insulated throughout with a foamed-in-place high density cell polyurethane insulation

Door(s)

- Stainless steel exterior with aluminum liner on the inside
- Positive self-closing doors with microswitch that shuts the evaporator fans off when the door is open
- Recessed handles are built into the door for easy opening and closing
- Locking door keep items inside secure after hours
- Stainless steel doors are field reversible

Shelving

- Adjustable plastic coated steel shelves that have a load capacity of up to 90 lbs per shelf

Model Features

- Incandescent interior lighting activated by door switch
- 4" casters come standard on all stainless steel models. 2 locking wheels and 2 non-locking wheels.



Solid Door Reach-In Freezers



Grista's Solid Door Reach-In Freezers are constructed of a heavy duty stainless steel exterior making them strong and durable enough to survive any kitchen environment. The cooling units are bottom mounted and slide out for easy maintenance and cleaning. All models come with 4" casters and plastic coated wire shelving that is easily removable to adjust the shelf height. The front digital controllers and LED readout makes it easy to adjust the interior temperature. These models are ETL Listed and ETL Sanitation. They are backed with a 1 year warranty on parts and labor and a 5 year warranty on the compressor.

Product Features

- Easy to clean 430 series stainless steel exterior
- Painted white aluminum interior
- Digital temperature control ranges 33-40°F in refrigerators and -7°F - 0°F in freezers
- 3 epoxy coated corrosion resistant shelves with 90 lb. capacity each
- Self-closing door with stay open feature beyond 90°
- Bottom mounted condensing unit positioned for easy maintenance
- Preprogrammed digital control featuring auto defrost cycle
- Foamed in place insulation helps provide strength while helping to maintain internal temperature
- Eco-friendly R290 hydrocarbon refrigerant
- Ships complete with casters

GRFZ-1D



GRFZ-2D



Specifications

Model Number	GRFZ-1D	GRFZ-2D
Doors	1	2
Shelves	3	6
Net Volume (Cu. Ft.)	23 Cu. Ft.	48 Cu. Ft.
Overall Dimensions (in)	29"W x 32"D x 82"H	54"W x 32"D x 82"H
Interior Dimensions (in)	24"W x 27"D x 60"H	49"W x 27"D x 60"H
Horsepower	3/4	1
Refrigerant	R290	R290
Voltage/Hertz/Phase	115/60/1	115/60/1
Amps	7.1	10.7
Net Weight (lbs)	287 lbs	474 lbs
Gross Weight (lbs)	346 lbs	525 lbs
Shipping Dimensions (in)	31"L x 35"W x 83"H	56"L x 35"W x 83"H

CALL FOR MORE INFO: 1.800.223.7750

VISIT: www.admiralcraft.com



by



Admiral Craft

Equipment Corp.

Solid Door Reach-In Freezers

Plan Views

GRFZ-1D

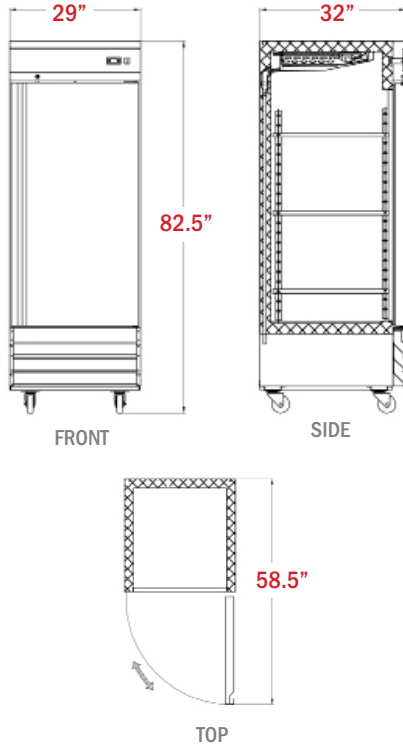

GRFZ-2D

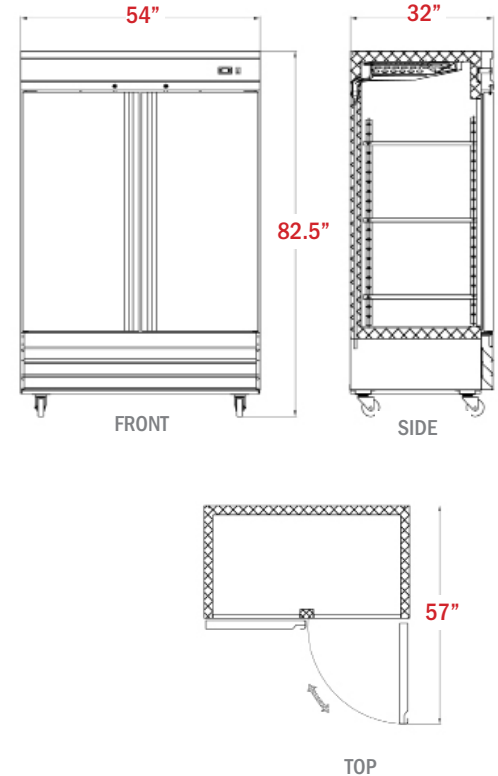

Features

Cooling System

- Freezer units use environmentally friendly R290 refrigerant and maintain a temperature range of 33°F - 40°F
- Bottom mounted cooling unit slides out for easy cleaning and maintenance and allows for storage area on top of the unit
- Rugged built axial evaporator fans run efficiently with low velocity and high volume air flow

Electrical Control

- Electric LED temperature controller provides a digital display of cabinet temperatures and allows for easy temperature adjustments when necessary
- Temperature controller initiates automatic defrost schedule for worry free use
- 7 foot power cord with NEMA 5-15 plug



Cabinet Construction

- Exterior is constructed of 430 stainless steel including the doors
- Interior is constructed of a painted aluminum liner
- The cabinet is insulated throughout with a foamed-in-place high density cell polyurethane insulation

Door(s)

- Stainless steel exterior with aluminum liner on the inside
- Positive self-closing doors with microswitch that shuts the evaporator fans off when the door is open
- Recessed handles are built into the door for easy opening and closing
- Locking door keep items inside secure after hours
- Stainless steel doors are field reversible

Shelving

- Adjustable plastic coated steel shelves that have a load capacity of up to 90 lbs per shelf

Model Features

- Incandescent interior lighting activated by door switch
- 4" casters come standard on all stainless steel models. 2 locking wheels and 2 non-locking wheels.

CALL FOR MORE INFO: 1.800.223.7750

VISIT: www.admiralcraft.com



Undercounter Refrigerators



Grista's Undercounter Refrigerators are constructed of heavy duty stainless steel making them strong and durable enough to survive in any kitchen environment. These units are perfect for adding more storage space anywhere you need. The flat stainless steel countertop allows for them to be used as a separate workstation. All undercounter units come with 4" casters and plastic coated wire shelving. These models are ETL Listed and ETL Sanitation. They are backed with a 1 year warranty on parts and labor and a 5 year warranty on the compressor.

Product Features

- 430 series stainless steel exterior
- Painted aluminum interior
- Environmentally-friendly R290 refrigerant
- Precise digital temperature controller with LED display
- Foamed-in-place polyurethane high density cell insulation throughout the entire cabinet
- Automatic defrosting
- Removable door gasket
- Recessed door handles
- (4) 4" casters (2 locking and 2 non-locking)



GRUCRF-27



GRUCRF-48



Specifications

Model Number	GRUCRF-27	GRUCRF-48
Doors	1	2
Shelves	1	2
Net Volume (Cu. Ft.)	6.3 Cu. Ft	12 Cu. Ft
Overall Dimensions (in)	27"W x 29.5"D x 35.2"H	47.2"W x 29.5"D x 35.2"H
Interior Dimensions (in)	22"W x 23"D x 23.5"H	42.5"W x 23"D x 23.5"H
Horsepower	1/6	1/5
Refrigerant	R290	R290
Voltage/Hertz/Phase	115/60/1	115/60/1
Amps	1.9	2.7
Net Weight (lbs)	169 lbs	238 lbs
Gross Weight (lbs)	220 lbs	299 lbs
Shipping Dimensions (in)	29.7"L x 32.5"W x 38.5"H	50"L x 32.5"W x 38.5"H



by



Admiral Craft

Equipment Corp.

Undercounter Refrigerators

Plan Views

GRUCFZ-27

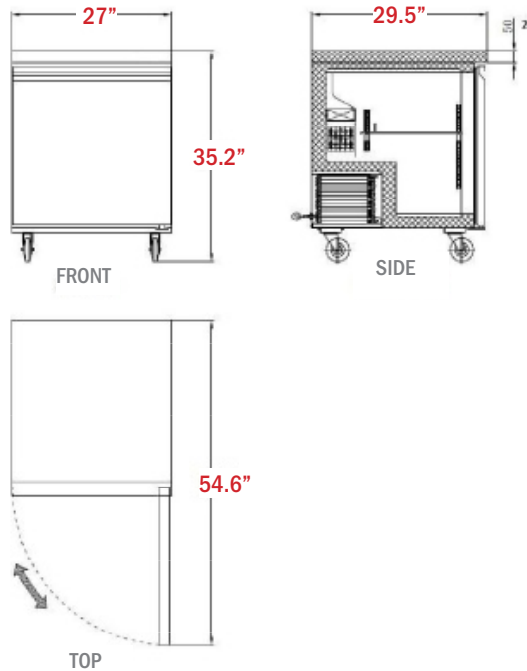

GRUCFZ-48

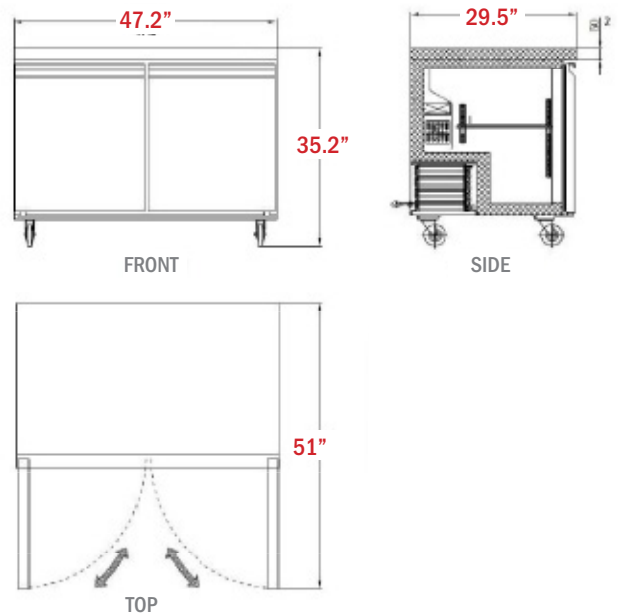

Features

Refrigeration System

- Refrigeration units use environmentally friendly R290 refrigerant
- Maintain a temperature range of 33°F–40°F
- Rugged built axial evaporator fans run efficiently with low velocity and high volume air flow

Electrical Control

- Electric LED temperature controller provides a digital display of cabinet temperatures and allows for easy temperature adjustments when necessary
- Temperature controller initiates automatic defrost schedule for worry free use
- 7 foot power cord with NEMA 5-15 plug



Cabinet Construction

- Exterior is constructed of 430 stainless steel including the doors
- The cabinet is insulated throughout with a foamed-in-place high density cell polyurethane insulation

Door(s)

- Stainless steel exterior with matching aluminum liner on the inside
- Positive self-closing doors with microswitch that shuts the evaporator fans off when the door is open
- Recessed handles are built into the door for easy opening and closing
- Removable door gasket for easy cleaning

Shelving

- Adjustable plastic coated steel shelves that have a load capacity of up to 90 lbs per shelf

Model Feature

- 4" casters come standard on all stainless steel models 2 locking and 2 non-locking.

CALL FOR MORE INFO: 1.800.223.7750

VISIT: www.admiralcraft.com



Undercounter Freezers



Grista's Undercounter Freezers are constructed of heavy duty stainless steel making them strong and durable enough to survive in any kitchen environment. These units are perfect for adding more storage space anywhere you need. The flat stainless steel countertop allows for them to be used as a separate workstation. All undercounter units come with 4" casters and plastic coated wire shelving. These models are ETL Listed and ETL Sanitation. They are backed with a 1 year warranty on parts and labor and a 5 year warranty on the compressor.

Product Features

- 430 series stainless steel exterior
- Painted aluminum interior
- Environmentally-friendly R290 refrigerant
- Precise digital temperature controller with LED display
- Foamed-in-place polyurethane high density cell insulation throughout the entire cabinet
- Automatic defrosting
- Removable door gasket
- Recessed door handles
- (4) 4" casters (2 locking and 2 non-locking)



NEMA 5-15 PLUG
120V/15 Amps



GRUCFZ-27



GRUCFZ-48



Specifications

Model Number	GRUCFZ-27	GRUCFZ-48
Doors	1	2
Shelves	1	2
Net Volume (Cu. Ft.)	6.3 Cu. Ft	12 Cu. Ft
Overall Dimensions (in)	27"W x 29.5"D x 35.2"H	47.2"W x 29.5"D x 35.2"H
Interior Dimensions (in)	22"W x 23"D x 23.5"H	42.5"W x 23"D x 23.5"H
Horsepower	1/5	1/4+
Refrigerant	R290	R290
Voltage/Hertz/Phase	115/60/1	115/60/1
Amps	2.1	3.12
Net Weight (lbs)	178 lbs	251 lbs
Gross Weight (lbs)	233 lbs	312 lbs
Shipping Dimensions (in)	29.7"L x 32.5"W x 38.5"H	50"L x 32.5"W x 38.5"H

CALL FOR MORE INFO: 1.800.223.7750

VISIT: www.admiralcraft.com

Undercounter Freezers

Plan Views

GRUCFZ-27

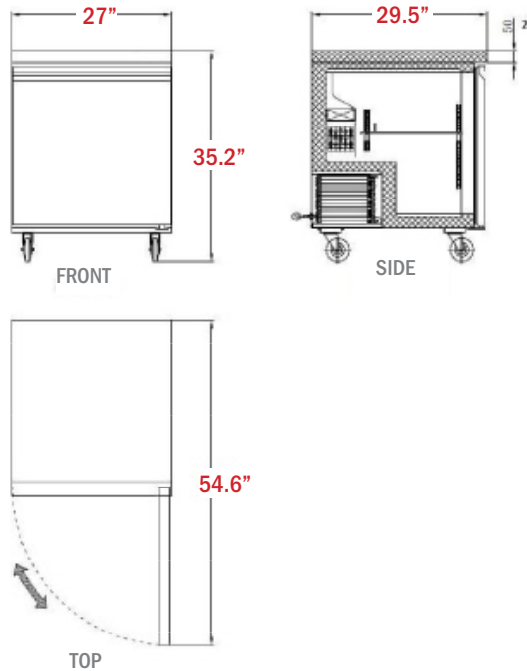

GRUCFZ-48

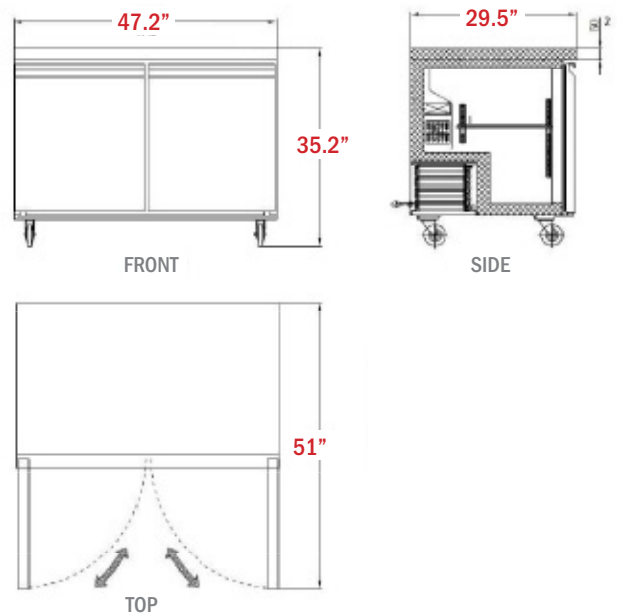

Features

Refrigeration System

- Refrigeration units use environmentally friendly R290 refrigerant
- Maintain a temperature range of -7°F – 0°F
- Rugged built axial evaporator fans run efficiently with low velocity and high volume air flow

Electrical Control

- Electric LED temperature controller provides a digital display of cabinet temperatures and allows for easy temperature adjustments when necessary
- Temperature controller initiates automatic defrost schedule for worry free use
- 7 foot power cord with NEMA 5-15 plug



Cabinet Construction

- Exterior is constructed of 430 stainless steel including the doors
- The cabinet is insulated throughout with a foamed-in-place high density cell polyurethane insulation

Door(s)

- Stainless steel exterior with matching aluminum liner on the inside
- Positive self-closing doors with microswitch that shuts the evaporator fans off when the door is open
- Recessed handles are built into the door for easy opening and closing
- Removable door gasket for easy cleaning

Shelving

- Adjustable plastic coated steel shelves that have a load capacity of up to 90 lbs per shelf

Model Feature

- 4" casters come standard on all stainless steel models 2 locking and 2 non-locking.



by



Admiral Craft

Equipment Corp.

Pizza Prep Tables



Grista's Pizza Prep Tables are constructed of heavy duty stainless steel making them strong and durable enough to survive in any kitchen environment. Store all of your toppings in the refrigerated pan rail that can hold a variety of different sized food pans up to 6" deep. The hinged insulated cover keeps the toppings cold when not in use. Store additional items below in the cabinet for quick access when needed. All pizza prep tables come with 4" casters, plastic coated wire shelving and a 19" extra deep, 3/4" thick polyethylene cutting board. These models are ETL Listed and ETL Sanitation. They are backed with a 1 year warranty on parts and labor and a 5 year warranty on the compressor.

Product Features

- 430 series stainless steel exterior
- Painted aluminum interior
- Environmentally-friendly R290 refrigerant
- Precise digital temperature controller with LED display
- 19" extra deep, 3/4" thick polyethylene cutting board
- Foamed-in-place polyurethane high density cell insulation throughout the entire cabinet
- Hinged insulated lid
- Removable door gasket
- Recessed door handles
- Plastic coated steel shelving
- (4) 4" casters (2 locking and 2 non-locking)



NEMA 5-15 PLUG
120V/15 Amps



GRPZ-2D

GRPZ-3D



Specifications

Model Number	GRPZ-2D	GRPZ-3D
Doors	2	2
Shelves	2	3
Net Volume (Cu. Ft.)	16.9 Cu. Ft	24 Cu. Ft
Overall Dimensions (in)	71"W x 32"D x 43"H	92"W x 31.5"D x 43"H
Interior Dimensions (in)	48.5"W x 23"D x 26"H	69.5"W x 23"D x 26"H
Horsepower	1/5	1/4+
Refrigerant	R290	R290
Voltage/Hertz/Phase	115/60/1	115/60/1
Amps	4.9	7.2
Net Weight (lbs)	431 lbs	565 lbs
Gross Weight (lbs)	563 lbs	719 lbs
Shipping Dimensions (in)	76"L x 36"W x 46"H	97"L x 36"W x 46"H

CALL FOR MORE INFO: 1.800.223.7750

VISIT: www.admiralcraft.com

Pizza Prep Tables

Plan Views

GRPZ-2D

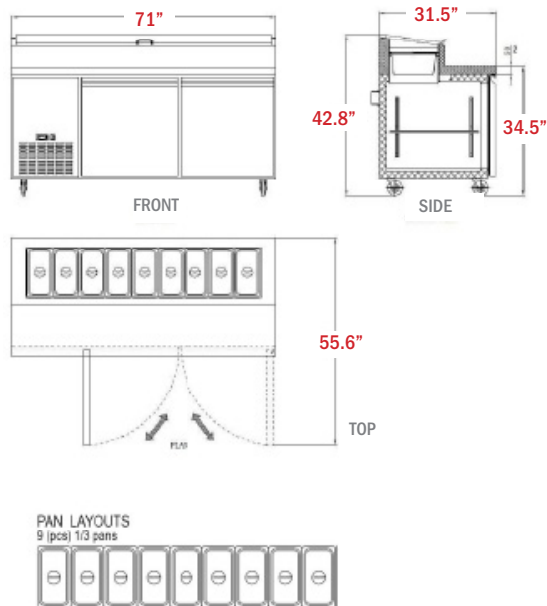

GRPZ-3D

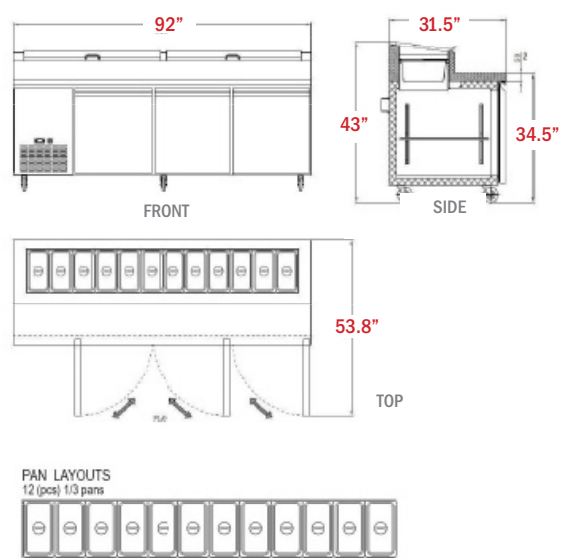

Features

Refrigeration System

- Refrigeration units use environmentally friendly R290 refrigerant
- Maintain a temperature range of 33°F–40°F
- Rugged built axial evaporator fans run efficiently with low velocity and high volume air flow

Electrical Control

- Electric LED temperature controller provides a digital display of cabinet temperatures and allows for easy temperature adjustments when necessary
- Temperature controller initiates automatic defrost schedule for worry free use
- 7 foot power cord with NEMA 5-15 plug

Cabinet Construction

- Exterior is constructed of 430 stainless steel including the doors
- The cabinet is insulated throughout with a foamed-in-place high density cell polyurethane insulation

Door(s)

- Stainless steel exterior with matching aluminum liner on the inside
- Positive self-closing doors with micro-switch that shuts the evaporator fans off when the door is open
- Recessed handles are built into the door for easy opening and closing
- Removable door gasket for easy cleaning

Shelving

- Adjustable plastic coated steel shelves that have a load capacity of up to 90 lbs per shelf

Model Features

- 19" extra deep, 3/4" thick polyethylene cutting board that runs the full length of the unit
- Insulated hinged lid to keep food cold while not in use
- 4" casters come standard on all stainless steel models 2 locking and 2 non-locking.
- 3/4" thick poly cutting board
- Clear plastic food pans included



Salad/Sandwich Prep Tables



Grista's Salad/Sandwich Prep Tables are constructed of heavy duty stainless steel them strong and durable enough to survive in any kitchen environment. Store all of your condiments, meats and vegetables in the cold topping area that can hold a variety of different sized food pans up to 6" deep. The hinged insulated cover keeps the food items cold when not in service. Store additional items below in the cabinet for quick access when needed. All salad/sandwich prep tables come with 4" casters, plastic coated wire shelving and a 3/4" thick polyethylene cutting board. These models are ETL Listed and ETL Sanitation. They are backed with a 1 year warranty on parts and labor and a 5 year warranty on the compressor.

Product Features

- 430 series stainless steel exterior
- Painted aluminum interior
- Environmentally-friendly R290 refrigerant
- Precise digital temperature controller with LED display
- Foamed-in-place polyurethane high density cell insulation throughout the entire cabinet
- Hinged insulated lid
- Removable door gasket
- Recessed door handles
- 3/4" thick removable polyethylene cutting board
- Clear plastic food pans included
- (4) 4" casters (2 locking and 2 non-locking)



GRSL-1D



GRSL-2D



GRSL-2D/60



Specifications

Model Number	GRSL-1D	GRSL-2D	GRSL-2D/60
Doors	1	2	2
Shelves	1	2	2
Net Volume (Cu. Ft.)	6 Cu. Ft	12 Cu. Ft	15 Cu. Ft
Overall Dimensions (in)	27.5"W x 29.5"D x 42.3"H	47"W x 30.5"D x 42.3"H	60"W x 30.5"D x 42.3"H
Interior Dimensions (in)	24"W x 24"D x 23.5"H	43"W x 24"D x 23.5"H	56"W x 24"D x 23.5"H
Horsepower	1/5	1/4+	1/4+
Refrigerant	R290	R290	R290
Voltage/Hertz/Phase	115/60/1	115/60/1	115/60/1
Amps	4.4	6.1	6.7
Net Weight (lbs)	187 lbs	271 lbs	319 lbs
Gross Weight (lbs)	255 lbs	394lbs	451 lbs
Shipping Dimensions (in)	32"L x 34"W x 45.5"H	51"L x 34"W x 45.5"H	66"L x 34"W x 45.5"H

CALL FOR MORE INFO: 1.800.223.7750

VISIT: www.admiralcraft.com

Salad/Sandwich Prep Tables

Plan Views

GRSL-1D

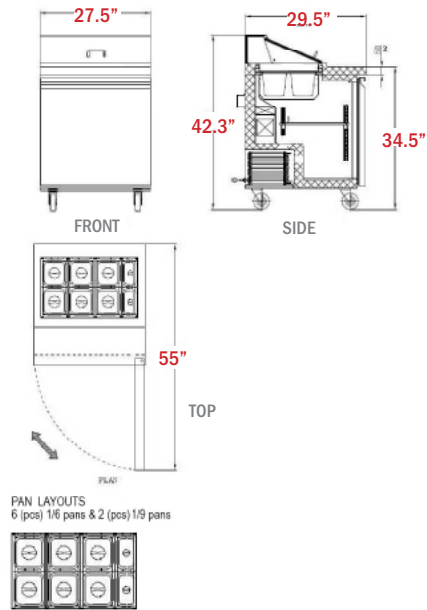

GRSL-2D

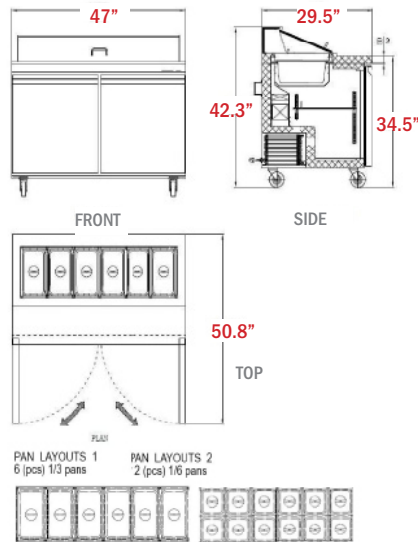

GRSL-2D/60

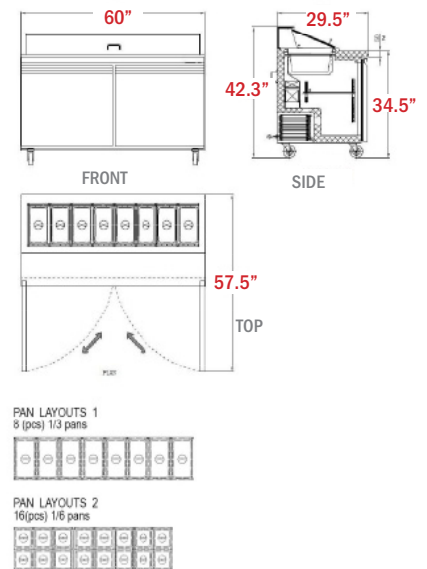

Features

Refrigeration System

- Refrigeration units use environmentally friendly R290 refrigerant
- Maintain a temperature range of 33°F–40°F
- Rugged built axial evaporator fans run efficiently with low velocity and high volume air flow

Electrical Control

- Electric LED temperature controller provides a digital display of cabinet temperatures and allows for easy temperature adjustments when necessary
- Temperature controller initiates automatic defrost schedule for worry free use
- 7 foot power cord with NEMA 5-15 plug

Cabinet Construction

- Exterior is constructed of 430 stainless steel including the doors
- The cabinet is insulated throughout with a foamed-in-place high density cell polyurethane insulation

Door(s)

- Stainless steel exterior with matching aluminum liner on the inside
- Positive self-closing doors with microswitch that shuts the evaporator fans off when the door is open
- Recessed handles are built into the door for easy opening and closing
- Removable door gasket for easy cleaning

Shelving

- Adjustable plastic coated steel shelves that have a load capacity of up to 90 lbs per shelf

Model Features

- 19" extra deep, 3/4" thick polyethylene cutting board that runs the full length of the unit
- Insulated hinged lid to keep food cold while not in use
- 4" casters come standard on all stainless steel models 2 locking and 2 non-locking.
- 3/4" thick poly cutting board
- Clear plastic food pans included



Mega Top Salad/Sandwich Prep Tables



Grista's Mega Top Salad/Sandwich Prep Tables are constructed of heavy duty stainless steel making them strong and durable enough to survive in any kitchen environment. Store all of your condiments, meats and vegetables in the cold topping area that can hold a variety of different sized food pans up to 6" deep. The oversized hinged insulated cover keeps the food items cold when not in service. Store additional items below in the cabinet for quick access when needed. All salad/sandwich prep tables come with 4" casters, plastic coated wire shelving and a 3/4" thick polyethylene cutting board. These models are ETL Listed and ETL Sanitation. They are backed with a 1 year warranty on parts and labor and a 5 year warranty on the compressor.

Product Features

- 430 series stainless steel exterior
- Painted aluminum interior
- Environmentally-friendly R290 refrigerant
- Precise digital temperature controller with LED display
- Foamed-in-place polyurethane high density cell insulation throughout the entire cabinet
- Oversized hinged insulated lid
- Removable door gasket
- Recessed door handles
- 3/4" thick removable polyethylene cutting board
- Clear plastic food pans included
- (4) 4" casters (2 locking and 2 non-locking)



GRSLM-2D



Specifications

Model Number	GRSLM-2D
Doors	2
Shelves	2
Net Volume (Cu. Ft.)	12 Cu. Ft
Overall Dimensions (in)	47"W × 34"D × 46"H
Interior Dimensions (in)	43"W × 24"D × 24"H
Horsepower	1/4+
Refrigerant	R290
Voltage/Hertz/Phase	115/60/1
Amps	6.1
Net Weight (lbs)	282 lbs
Gross Weight (lbs)	407 lbs
Shipping Dimensions (in)	51"L × 34"W × 49"H

CALL FOR MORE INFO: 1.800.223.7750

VISIT: www.admiralcraft.com



Mega Top Salad/Sandwich Prep Tables

Plan Views

GRSLM-2D

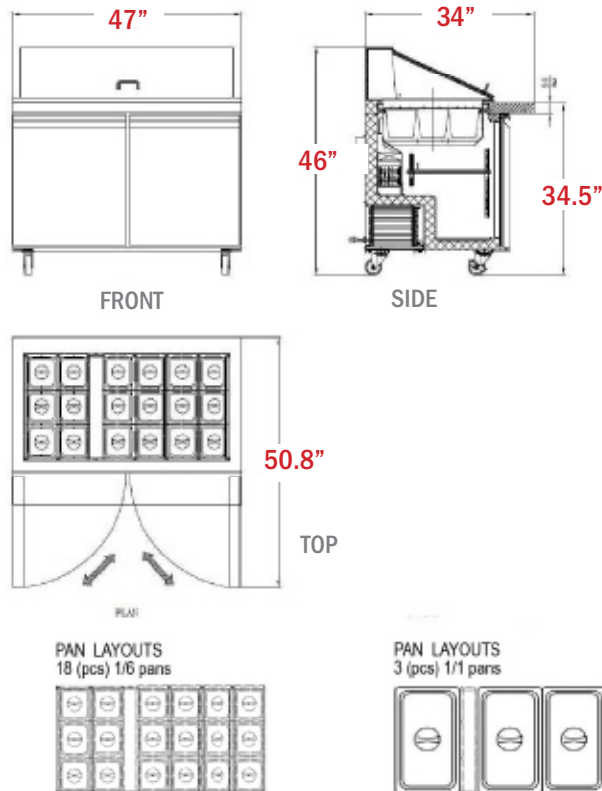

Features

Refrigeration System

- Refrigeration units use environmentally friendly R290 refrigerant
- Maintain a temperature range of 33°F–40°F
- Rugged built axial evaporator fans run efficiently with low velocity and high volume air flow

Electrical Control

- Electric LED temperature controller provides a digital display of cabinet temperatures and allows for easy temperature adjustments when necessary
- Temperature controller initiates automatic defrost schedule for worry free use
- 7 foot power cord with NEMA 5-15 plug

Cabinet Construction

- Exterior is constructed of 430 stainless steel including the doors
- The cabinet is insulated throughout with a foamed-in-place high density cell polyurethane insulation

Door(s)

- Stainless steel exterior with matching aluminum liner on the inside
- Positive self-closing doors with micro-switch that shuts the evaporator fans off when the door is open
- Recessed handles are built into the door for easy opening and closing
- Removable door gasket for easy cleaning

Shelving

- Adjustable plastic coated steel shelves that have a load capacity of up to 90 lbs per shelf

Model Features

- 19" extra deep, 3/4" thick polyethylene cutting board that runs the full length of the unit
- Insulated hinged lid to keep food cold while not in use
- 4" casters come standard on all stainless steel models 2 locking and 2 non-locking.
- 3/4" thick poly cutting board
- Clear plastic food pans included

CALL FOR MORE INFO: 1.800.223.7750

VISIT: www.admiralcraft.com